

TECNA®

Advanced Resistance Welding Systems



3062÷3184

-  **PUNTATRICI PENSILI PNEUMATICHE DA PRODUZIONE A MEDIA FREQUENZA**
-  **MEDIUM FREQUENCY, AIR OPERATED PRODUCTION SPOT WELDING GUNS**
-  **MITTELFREQUENZ - PNEUMATISCHE PRODUKTIONS - PUNKTSCHWEISSZANGEN**

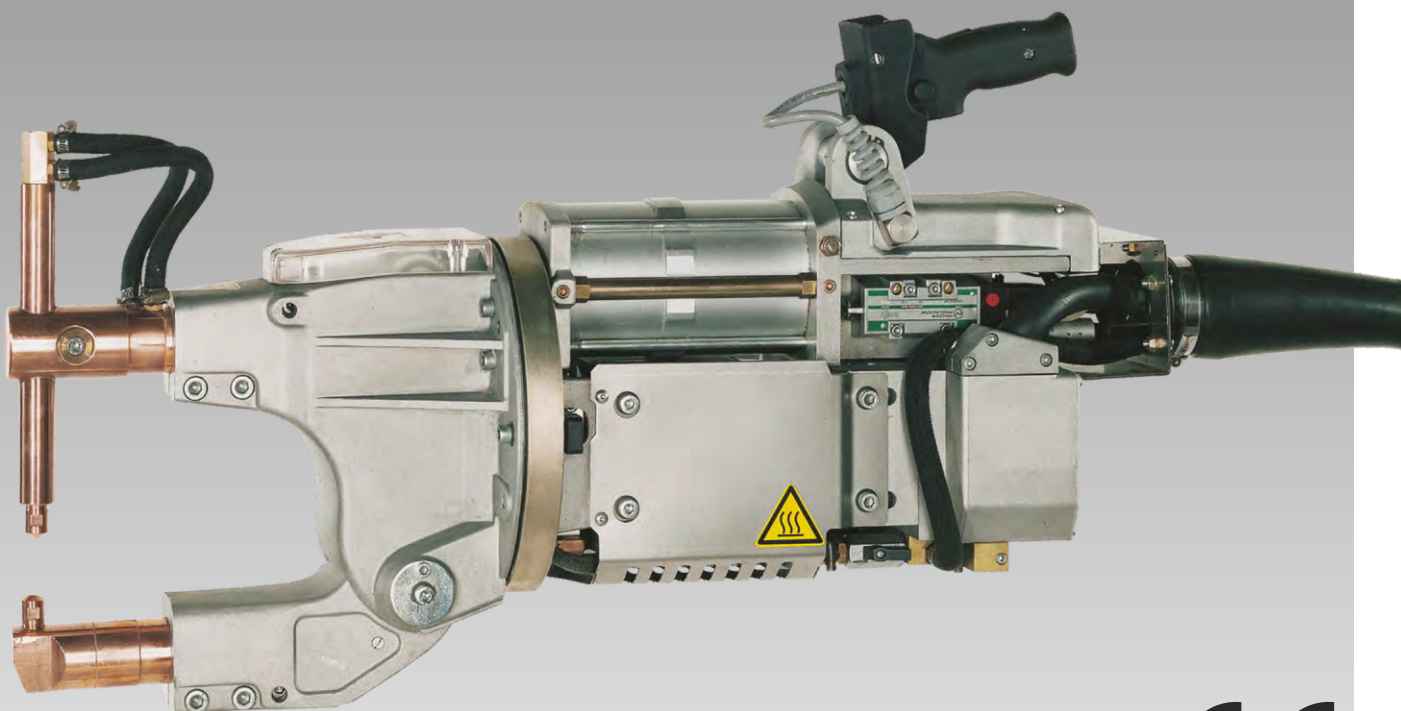
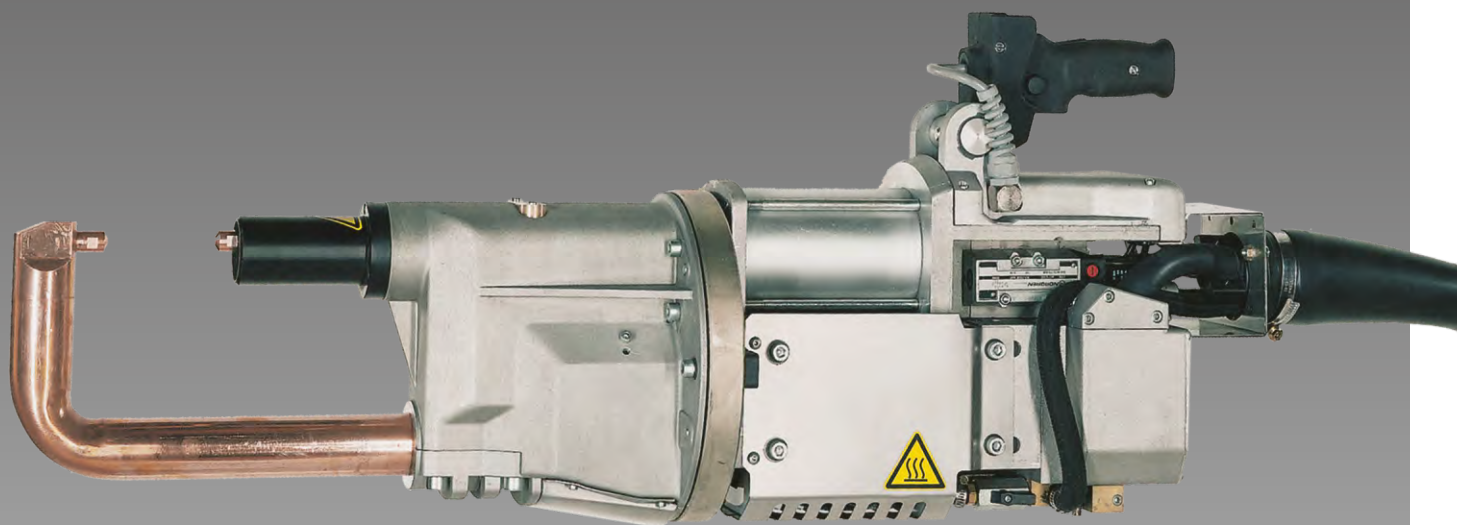

CE

The most advanced resistance welding machines

www.tecna.net

3062Q

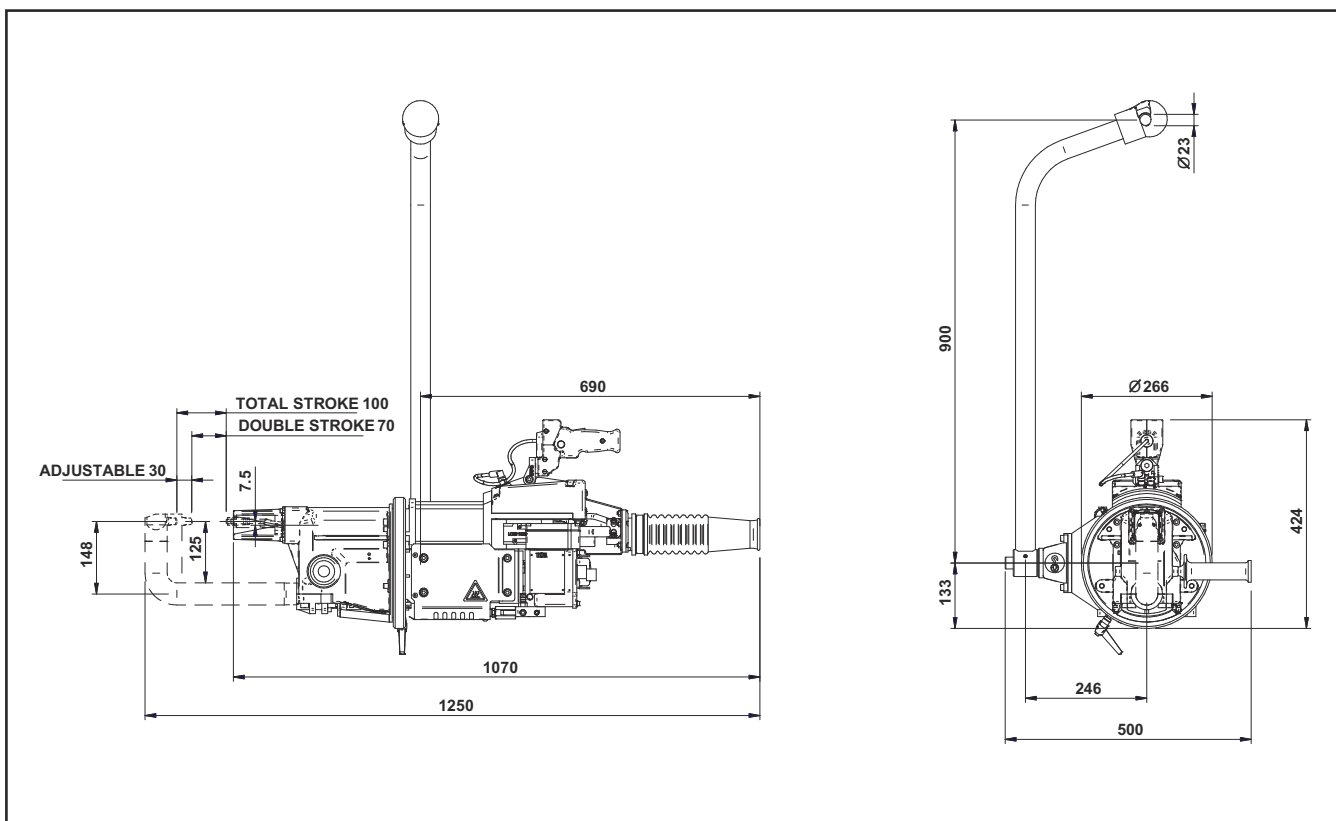
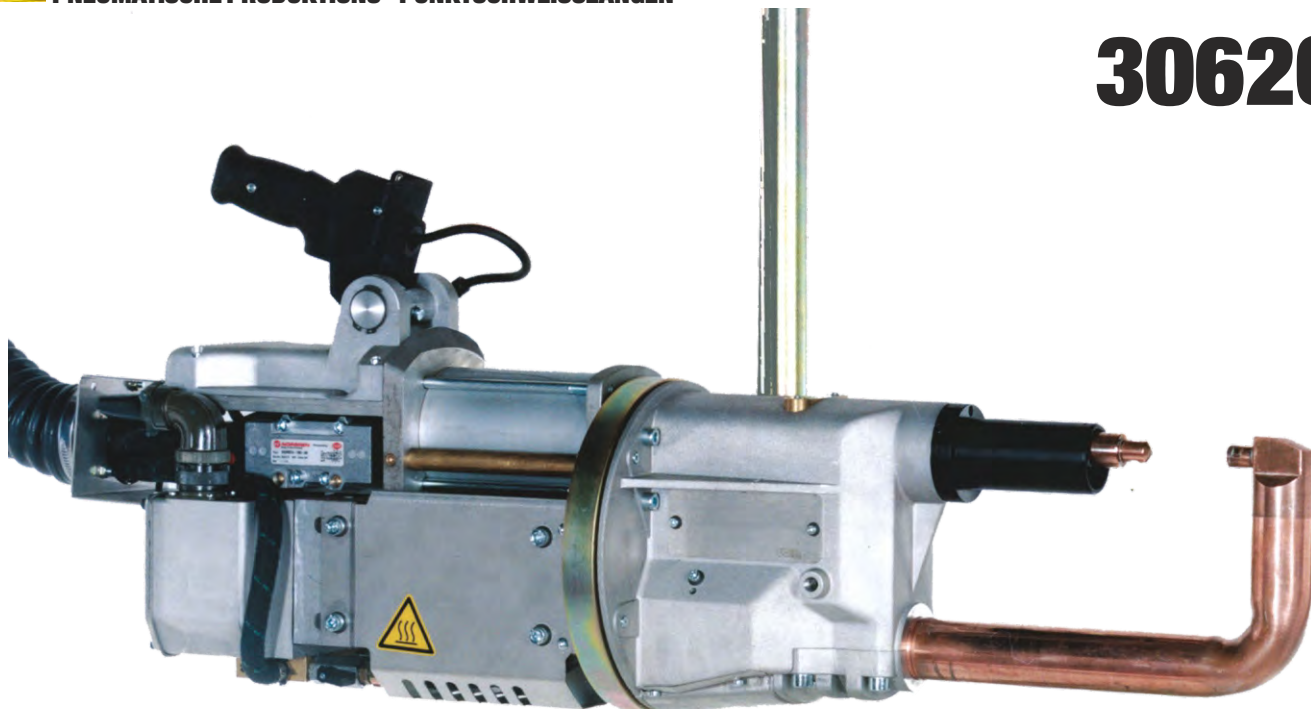

 BRACCI -
  ARMS -
  ARME

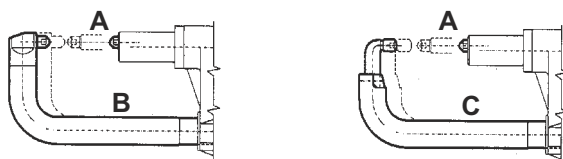

Art. / Item 3062			
BRACCI - ARMS - ARME Ø 45 CP			
L (mm)	A	B	C
	4401	4402	4403

ARTICOLO ITEM ARTIKEL	POTENZA POWER LEISTUNG		INTERASSE GAP ACHSABST.	FORZA daN FORCE daN KRAFT daN		ALES. CILINDRO CYLIND. BORE BOHR.ZYLINDER	CORRENTE CC. SC. CURRENT STROM CC	DIAMETRO INNESTO BRACCI ARMS TAPER DURCHM.EINSATZ ARME		PESO NETTO NET WEIGHT GEWICHT NETTO
	kVA AL 20%	kVA AL 50%		mm	A 6 bar			A 8 bar	Ø mm.	
3062	88	56	-	375	500	90	25	44	42	53

PESO NETTO CON SOSPENSIONE E SENZA BRACCI - NET WEIGHT WITH SUSPENSION AND WITHOUT ARMS - NETTO-GEWICHT MIT KUGELLAGERRUNDFÜHRUNG OHNE ARME

N.I.= NON ISOLATI - NOT INSULATED - NICHT ISOLIERT

I. = ISOLATI - INSULATED - ISOLIERT

3066Q

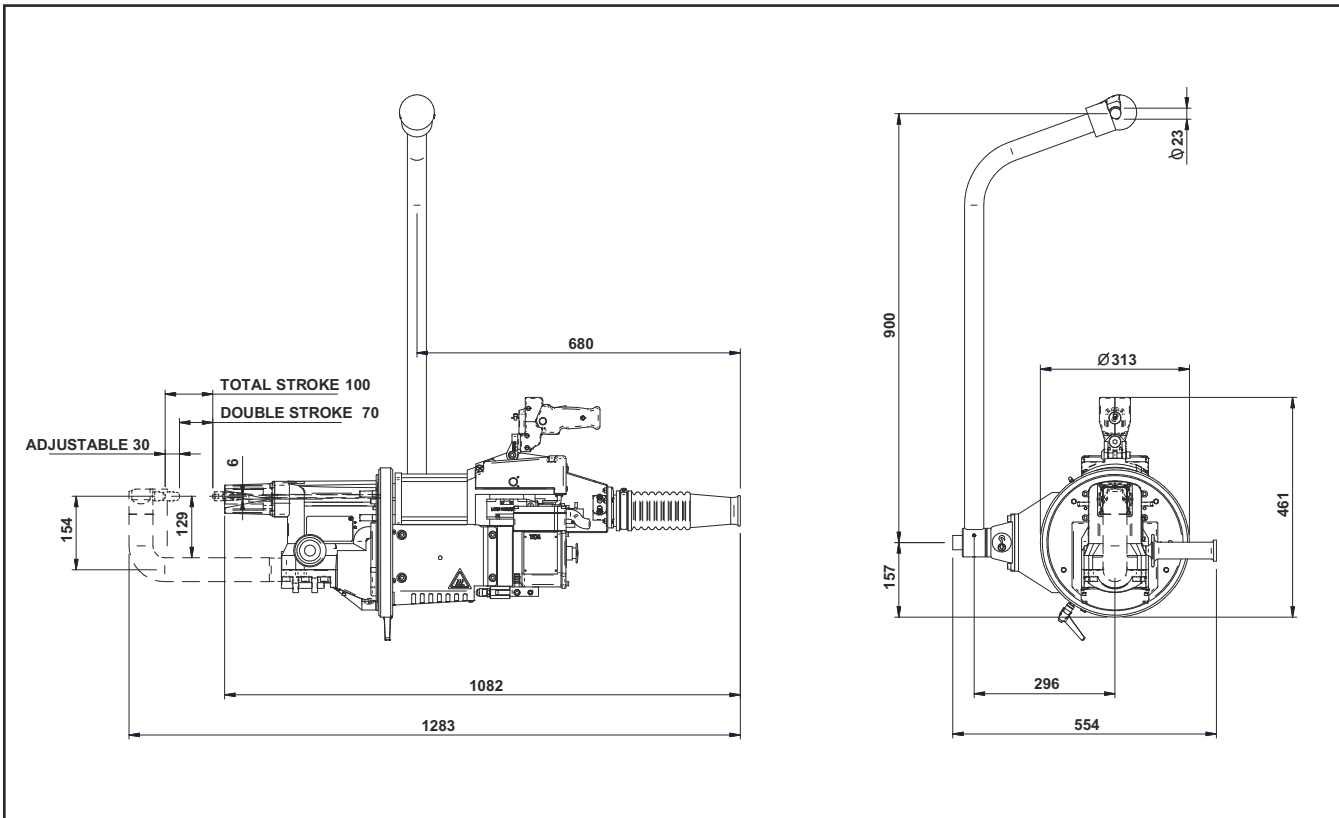
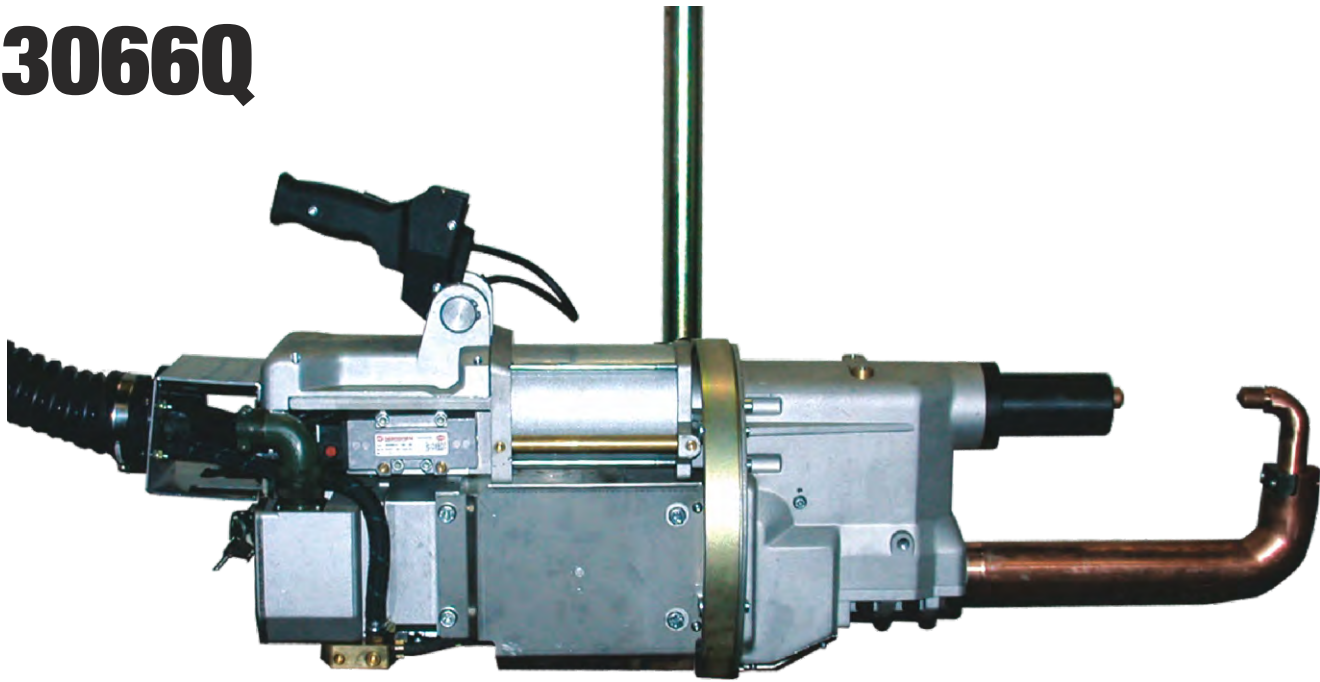

 BRACCI -  ARMS -  ARME

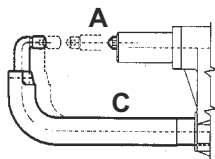
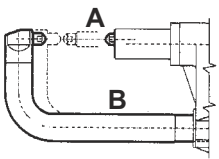

Art. / Item 3066			
BRACCI - ARMS - ARME Ø 50 CG			
L (mm)	A	B	C
	4410	4411	4412

ARTICOLO ITEM ARTIKEL	POTENZA POWER LEISTUNG		INTERASSE GAP ACHSABST.	FORZA daN FORCE daN KRAFT daN		ALES. CILINDRO CYLIND. BORE BOHR.ZYLINDER	CORRENTE CC. SC. CURRENT STROM CC	DIAMETRO INNESTO BRACCI ARMS TAPER DURCHM.EINSATZ ARME		PESO NETTO NET WEIGHT GEWICHT NETTO
	kVA AL 20%	kVA AL 50%	mm	A 6 bar	A 8 bar	Ø mm.	kA	N.I. mm.	I. mm.	kg
3066	142	90	-	465	620	100	30	49	47	63

PESO NETTO CON SOSPENSIONE E SENZA BRACCI - NET WEIGHT WITH SUSPENSION AND WITHOUT ARMS - NETTO-GEWICHT MIT KUGELLAGERRUNDFOHRUNG OHNE ARME

N.I.= NON ISOLATI - NOT INSULATED - NICHT ISOLIERT

I. = ISOLATI - INSULATED - ISOLIERT

3176

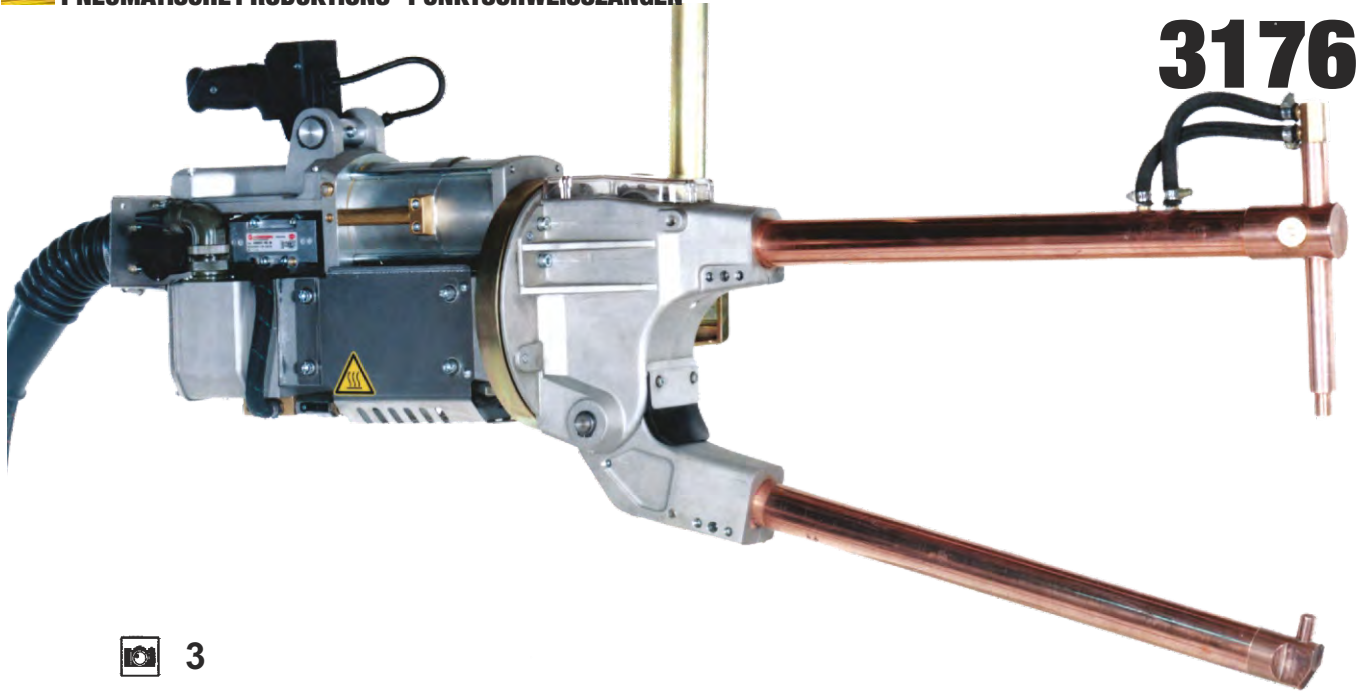

3

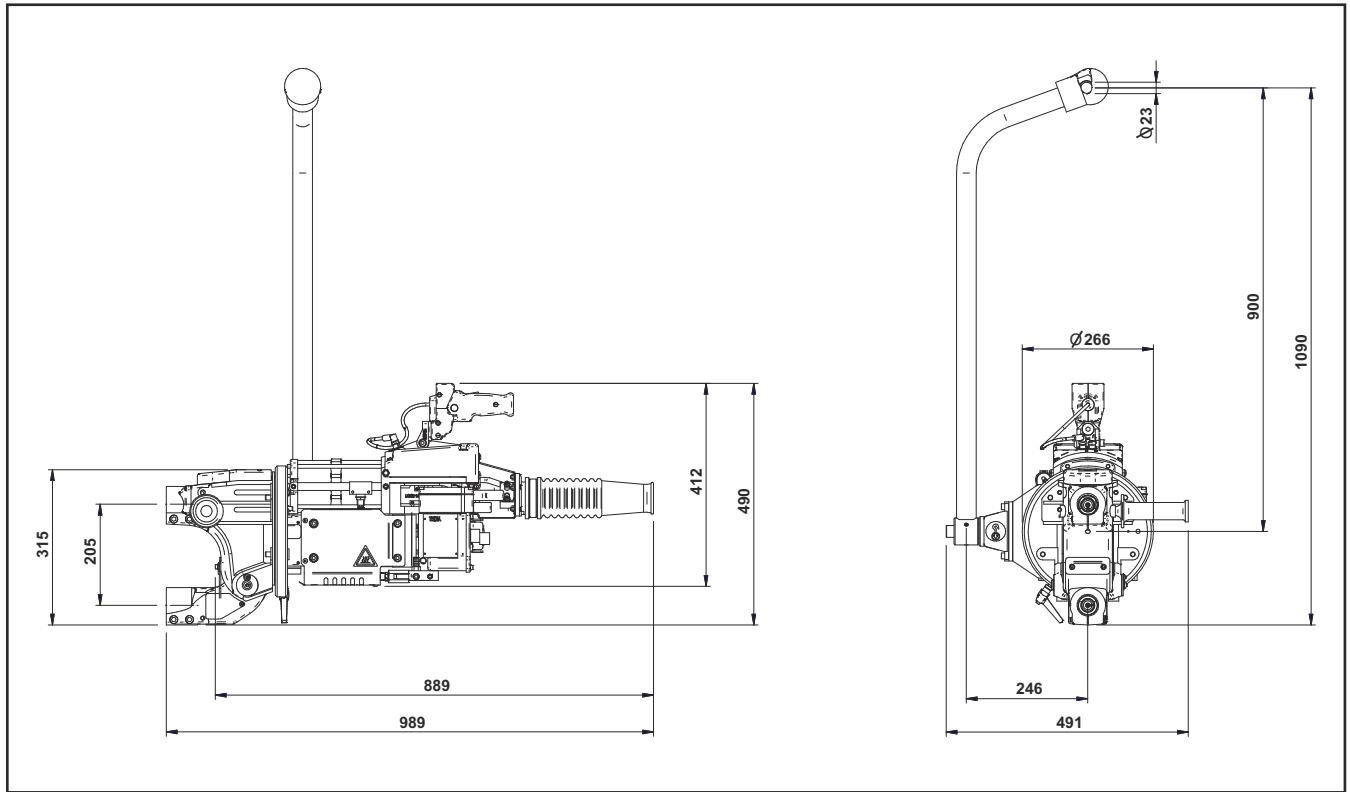

BRACCI - ARMS - ARME

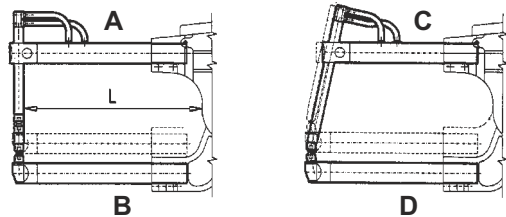

BRACCI - ARMS - ARME Ø 45 L							
L (mm)	A	B	C	D	F (6 bar) daN	F (8 bar) daN	Ø 45/kg
190	4460	4464	4461	4465	340	450	~5,3
250	4466	4470	4467	4471	270	360	~6,4
350	4472	4476	4473	4477	200	270	~8,3
508	4478	4482	4479	4483	150	195	~11,5
650	4484	4488	4485	4489	115	155	~14,2
800	4490	4494	4491	4495	95	130	~17

** NON PREVISTI* NOT AVAILABLE / ** NICHT VORGESEHEN

ARTICOLO ITEM ARTIKEL	POTENZA POWER LEISTUNG		INTERASSE GAP ACHSABST.	FORZA daN FORCE daN KRAFT daN		ALES. CILINDRO CYLIND. BORE BOHR.ZYLINDER	CORRENTE CC. SC. CURRENT STROM CC	DIAMETRO INNESTO BRACCI ARMS TAPER DURCHM.EINSATZ ARME		PESO NETTO NET WEIGHT GEWICHT NETTO
	kVA AL 20%	kVA AL 50%		mm	A 6 bar			A 8 bar	Ø mm.	
3176	88	56	205	340	450	100	25	44	42	55

PESO NETTO CON SOSPENSIONE E SENZA BRACCI - NET WEIGHT WITH SUSPENSION AND WITHOUT ARMS - NETTO-GEWICHT MIT KUGELLAGERRUNDFÜHRUNG OHNE ARME

N.I.= NON ISOLATI - NOT INSULATED - NICHT ISOLIERT

I. = ISOLATI - INSULATED - ISOLIERT

3177

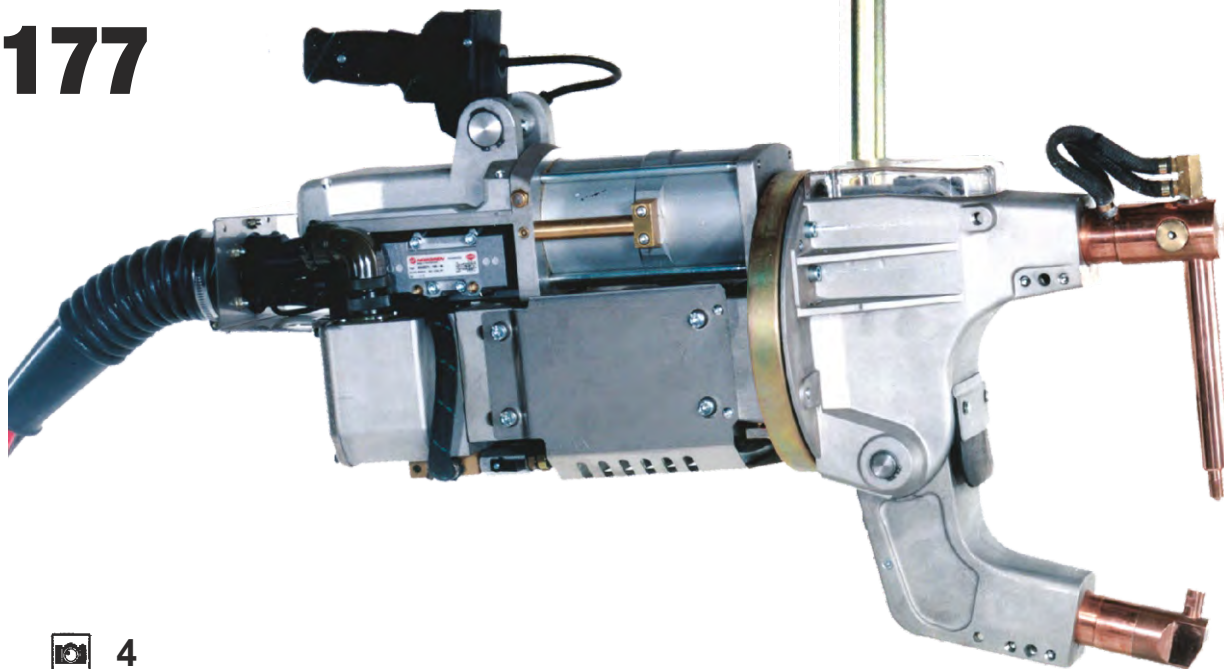

4

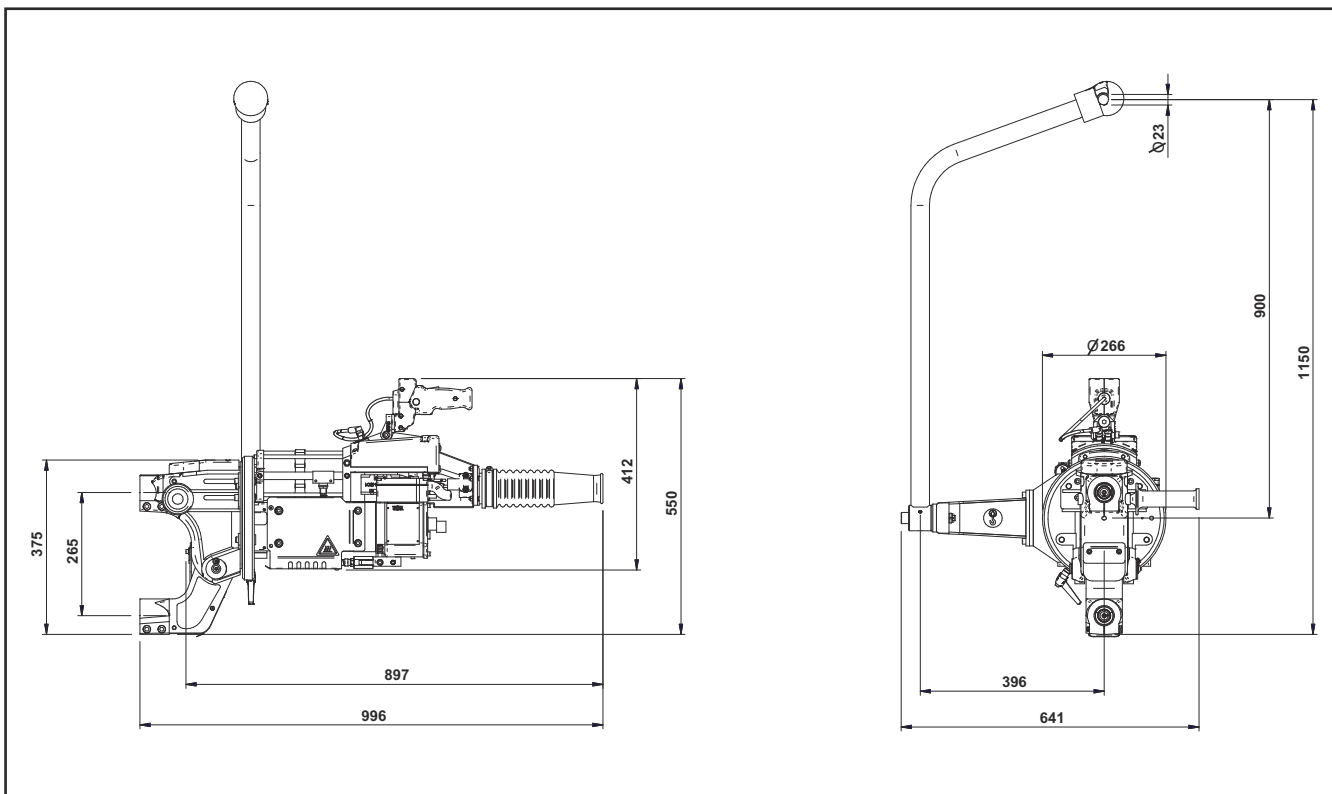

BRACCI - ARMS - ARME

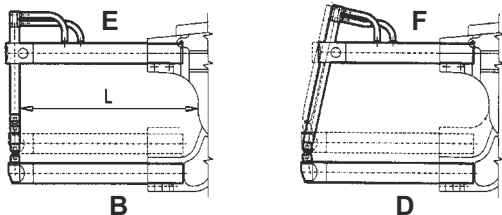

BRACCI - ARMS - ARME Ø 45 LL							
L (mm)	B	D	E	F	F (6 bar) daN	F (8 bar) daN	Ø 45/kg
190	**	**	**	**	340	450	~5,3
250	4470	4471	4468	4469	270	360	~6,4
350	4476	4477	4474	4475	200	270	~8,3
508	4482	4483	4480	4481	150	195	~11,5
650	4488	4489	4486	4487	115	155	~14,2
800	**	**	**	**	95	130	~17

** NON PREVISTI** NOT AVAILABLE / ** NICHT VORGESEHEN

ARTICOLO ITEM ARTIKEL	POTENZA POWER LEISTUNG		INTERASSE GAP ACHSABST.	FORZA daN FORCE daN KRAFT daN		ALES. CILINDRO CYLIND. BORE BOHR.ZYLINDER	CORRENTE CC. SC. CURRENT STROM CC	DIAMETRO INNESCO BRACCI ARMS TAPER DURCHM.EINSATZ ARME		PESO NETTO NET WEIGHT GEWICHT NETTO
	kVA AL 20%	kVA AL 50%		mm	A 6 bar			A 8 bar	N.I. mm.	
3177	88	56	265	340	450	100	25	44	42	55,5

PESO NETTO CON SOSPENSIONE E SENZA BRACCI - NET WEIGHT WITH SUSPENSION AND WITHOUT ARMS - NETTO-GEWICHT MIT KUGELLAGERGRUNDFÜHRUNG OHNE ARME
 N.I.= NON ISOLATI - NOT INSULATED - NICHT ISOLIERT I. = ISOLATI - INSULATED - ISOLIERT

3176-3177

3183

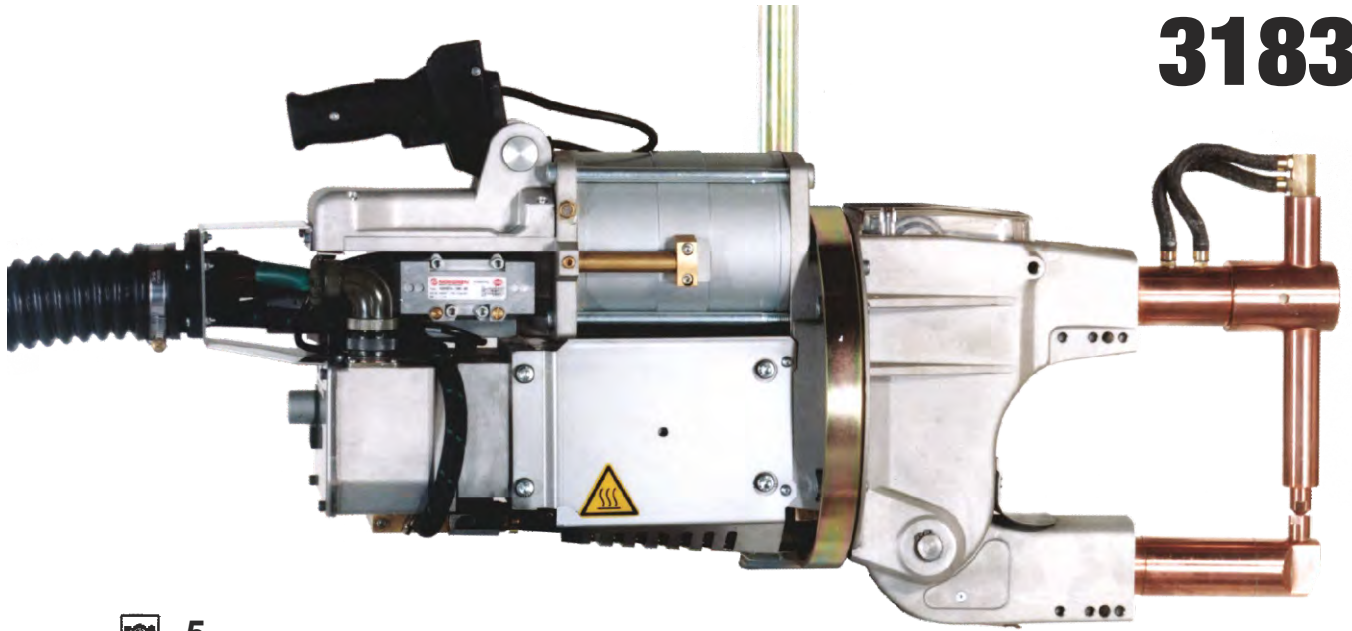

5

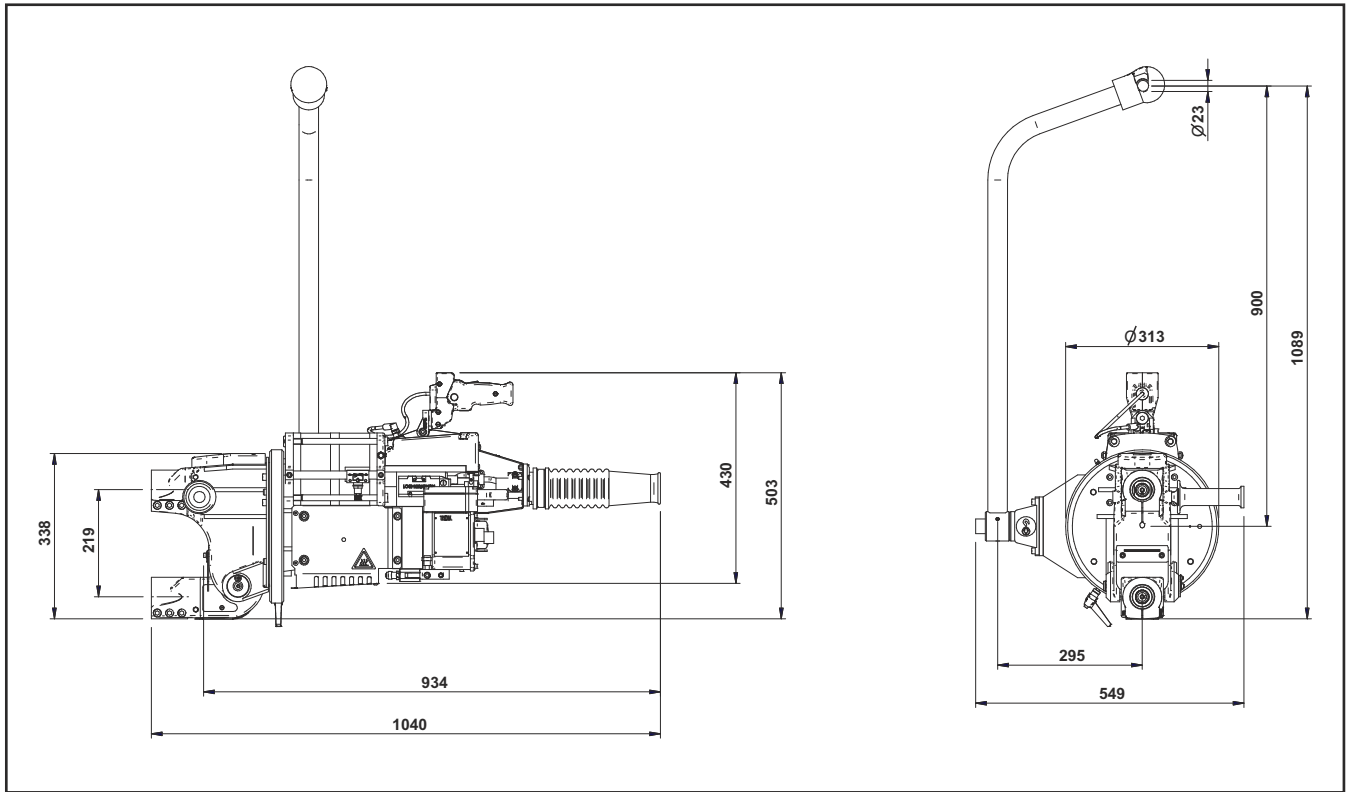

BRACCI - ARMS - ARME

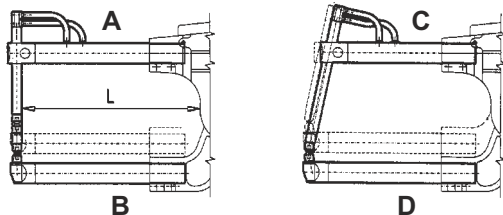

BRACCI - ARMS - ARME Ø 50 L							
L (mm)	A	B	C	D	F (6 bar) daN	F (8 bar) daN	Ø 50/kg
255	4420	4424	**	**	645	855	~9
408	4426	4430	4427	4431	430	575	~13
610	4432	4436	4433	4437	300	400	~17
820	4438	4442	4439	4443	230	305	~22
1030	4444	4448	**	**	185	245	~28
** NON PREVISTI* NOT AVAILABLE / ** NICHT VORGESEHEN							

ARTICOLO ITEM ARTIKEL	POTENZA POWER LEISTUNG		INTERASSE GAP ACHSABST.	FORZA daN FORCE daN KRAFT daN		ALES. CILINDRO CYLIND. BORE BOHR.ZYLINDER	CORRENTE CC. SC. CURRENT STROM CC	DIAMETRO INNESTO BRACCI ARMS TAPER DURCHM.EINSATZ ARME		PESO NETTO NET WEIGHT GEWICHT NETTO
	kVA AL 20%	kVA AL 50%		mm	A 6 bar			A 8 bar	Ø mm.	
3183	142	90	219	645	855	140	30	49	47	75
PESO NETTO CON SOSPENSIONE E SENZA BRACCI - NET WEIGHT WITH SUSPENSION AND WITHOUT ARMS - NETTO-GEWICHT MIT KUGELLAGERRUNDFÜHRUNG OHNE ARME										
N.I.= NON ISOLATI - NOT INSULATED - NICHT ISOLIERT						I. = ISOLATI - INSULATED - ISOLIERT				

3184

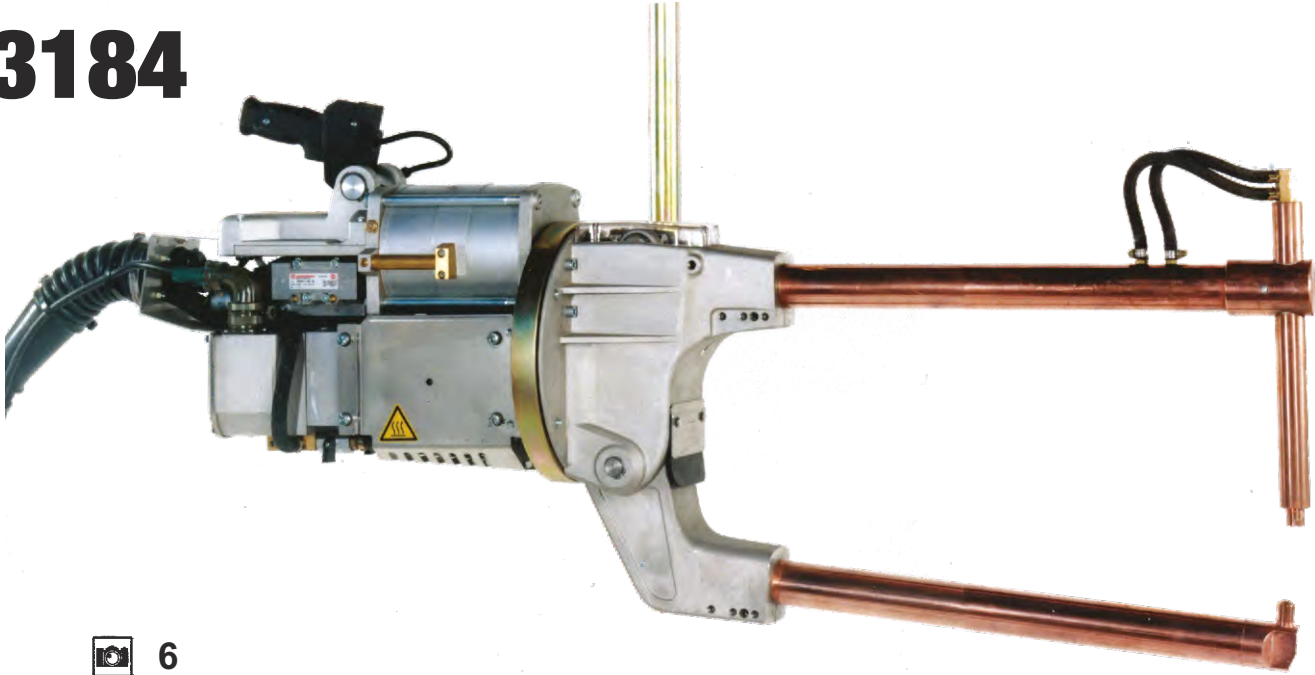

 6

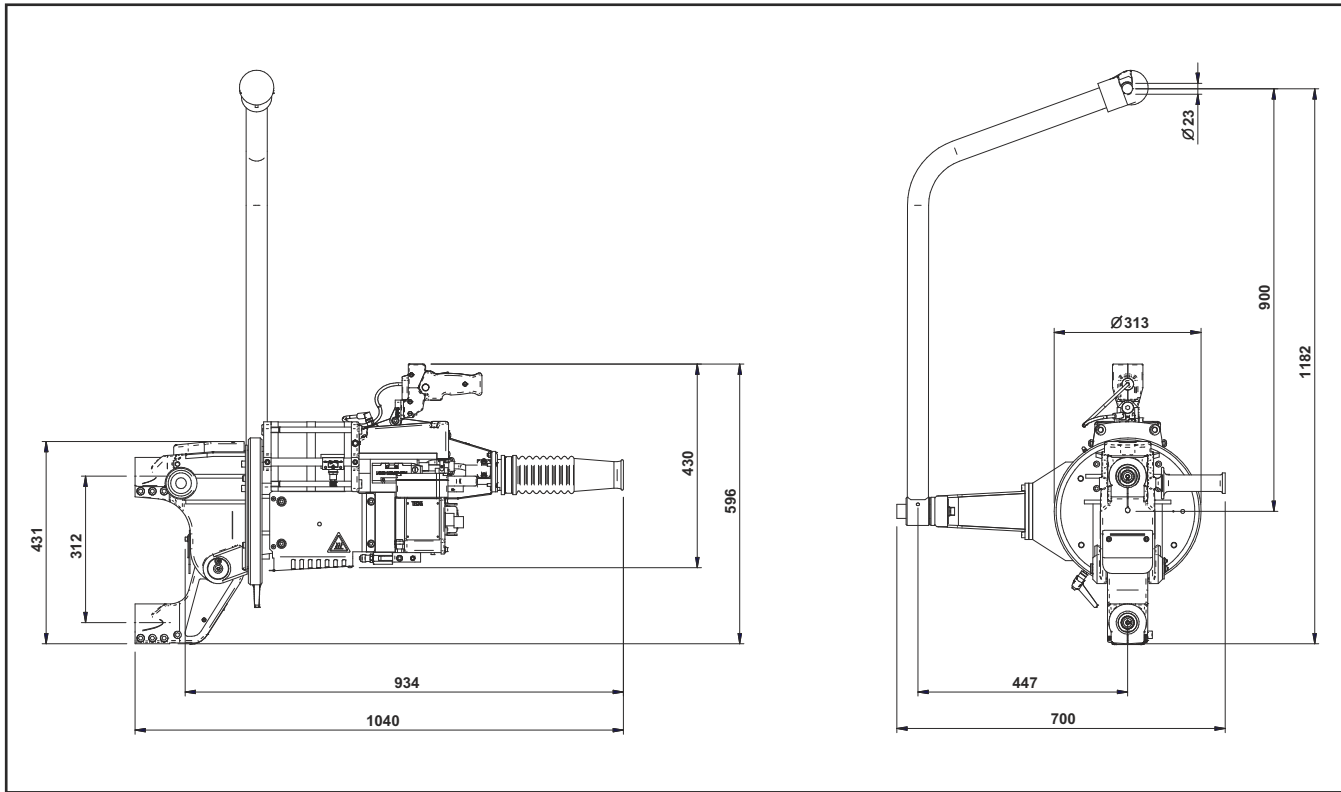

 BRACCI -  ARMS -  ARME

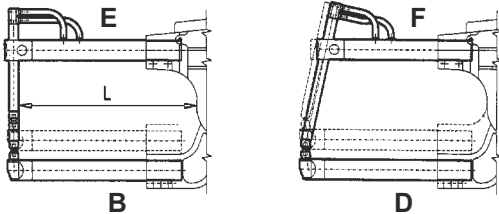

BRACCI - ARMS - ARME Ø 50 LL							
L (mm)	B	D	E	F	F (6 bar) daN	F (8 bar) daN	Ø 50/kg
255	4424	**	4422	**	645	855	~9
408	4430	4431	4428	4429	430	575	~13
610	4436	4437	4434	4435	300	400	~17
820	4442	4443	4440	4441	230	305	~22
1030	4448	**	4446	**	185	245	~28
** NON PREVISTI** NOT AVAILABLE / ** NICHT VORGESEHEN							

ARTICOLO ITEM ARTIKEL	POTENZA POWER LEISTUNG		INTERASSE GAP ACHSABST.	FORZA daN FORCE daN KRAFT daN		ALES. CILINDRO CYLIND. BORE BOHR.ZYLINDER	CORRENTE CC. SC. CURRENT STROM CC	DIAMETRO INNESTO BRACCI ARMS TAPER DURCHM.EINSATZ ARME		PESO NETTO NET WEIGHT GEWICHT NETTO
	kVA AL 20%	kVA AL 50%		mm	A 6 bar			A 8 bar	Ø mm.	
3184	142	90	312	645	855	140	30	49	47	76

PESO NETTO CON SOSPENSIONE E SENZA BRACCI - NET WEIGHT WITH SUSPENSION AND WITHOUT ARMS - NETTO-GEWICHT MIT KUGELLAGERRUNDFÜHRUNG OHNE ARME

N.I.= NON ISOLATI - NOT INSULATED - NICHT ISOLIERT

I. = ISOLATI - INSULATED - ISOLIERT

3183-3184



ARMADIO DI CONTROLLO PER SALDATRICE A MEDIA FREQUENZA

L'armadio di controllo, che comanda la saldatrice a media frequenza, integra l'inverter, il controllo di saldatura TE710, i dispositivi di protezione e sicurezza. Sono disponibili diverse taglie, dipendentemente dalla potenza della saldatrice.

CONTROLLO DI SALDATURA TE710

Programmazione semplificata con display alfanumerico LCD con messaggi nella lingua selezionata dall'utilizzatore.

300 programmi di saldatura memorizzabili, 16 dei quali richiamabili direttamente dall'esterno.

6 modalità di funzionamento: Corrente Costante, Potenza Costante, Tensione Costante, FIX, Energia Costante, DYNAMIC mode.

Limiti in: Corrente, Tensione agli elettrodi, Energia, Potenza, Percentuale di utilizzo dell'inverter, Resistenza iniziale e finale del materiale da saldare; limite sullo spessore e sull'indentazione del materiale (opzionale).

Regolazione dei tempi di saldatura in millesimi di secondo.

Chiave asportabile per il blocco della programmazione.



CONTROL CABINET FOR MEDIUM FREQUENCY WELDERS

The control cabinet, which controls the medium frequency welder, integrates the inverter, the welding control unit TE710, the protection and safety devices. There are different sizes available, depending on the power of the welder.

WELDING CONTROL UNIT TE710

Easy programming with LCD alphanumeric display showing messages in the language selected by user.

300 welding programs recordable, 16 programs directly selectable from external device

6 functions modes: constant current, constant power, constant voltage, FIX, constant energy, DYNAMIC mode

Limits in: current, voltage at the electrodes, energy, power, percentage of utilization of the inverter, initial and final resistance of the material welded, limit on the thickness and on the indentation of the material (optional)

Adjustment of the welding time in thousands of a second.

Removable key for programming lock.



STEUERUNGSSCHRANK FÜR MITTELFREQUENZSCHWEISSMASCHINEN

Der Steuerungsschrank, der die Mittelfrequenz-Schweissmaschine steuert, integriert den Inverter, die Schweiss-Steuerung TE710, die Schutz- u. Sicherheitsvorrichtungen. Es gibt je nach Leistung der Schweissmaschine verschiedene Grössen.

SCHWEISS-STEUERUNG TE 710

Vereinfachte Programmierung mit alphanumerischem Display LCD mit Anzeige in der vom Bediener gewählten Sprache.

300 speicherbar Schweissprogramme, davon 16 direkt extern abrufbar.

6 Funktionsmodalitäten: Konstantstrom, Konstantleistung, Konstantspannung, FIX, Konstantenergie, Modalität DYNAMIC

Grenzwerte für: Strom, Spannung an den Elektroden, Leistung, prozentuale Anwendung des Inverters, Anfangs- u. Endwiderstand des zu schweisenden; Materials, Grenzwert bezüglich Dicke und Eindringtiefe des Materials (Option).

Schweissung mit drei verschiedenen Einstellungsfolgen, um gewünschte Stromprofile zu erreichen.

Zähler der ausgeführten Schweissungen und Programmiermöglichkeit der auszuführenden Punkteanzahl.

1556W - 1557W - 1558W

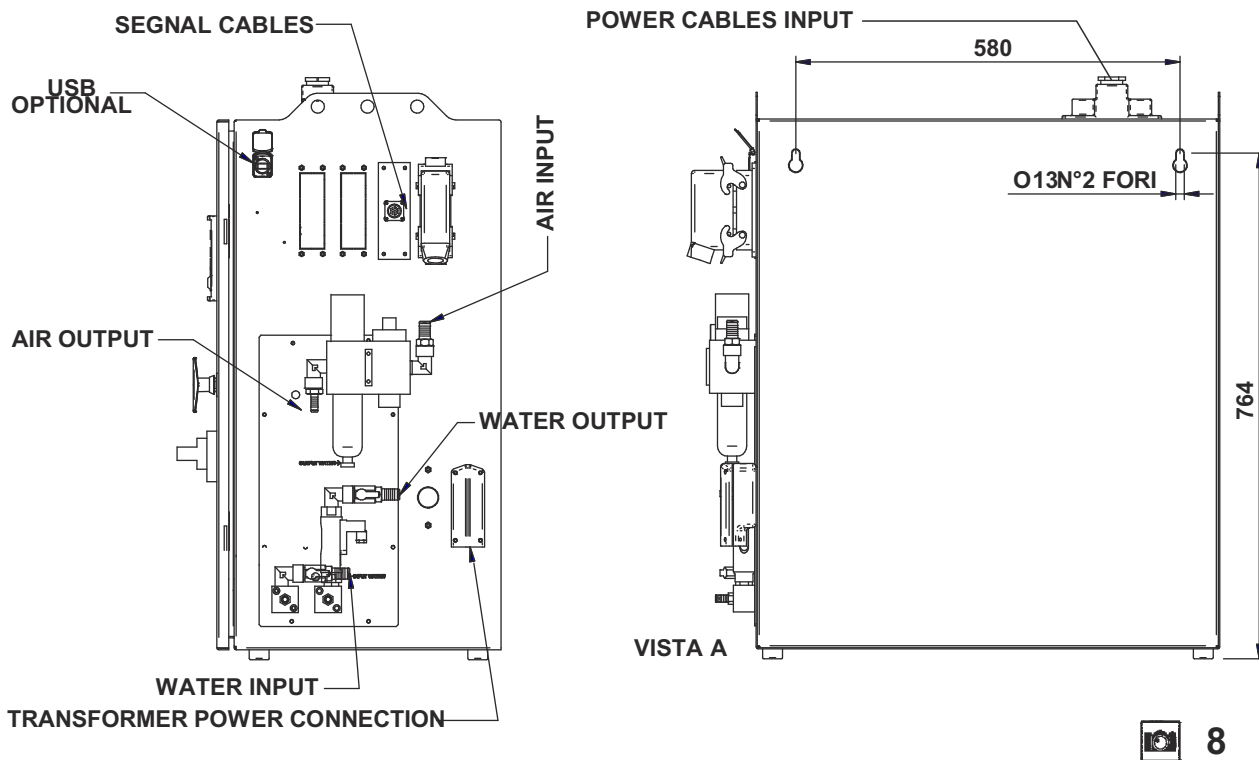
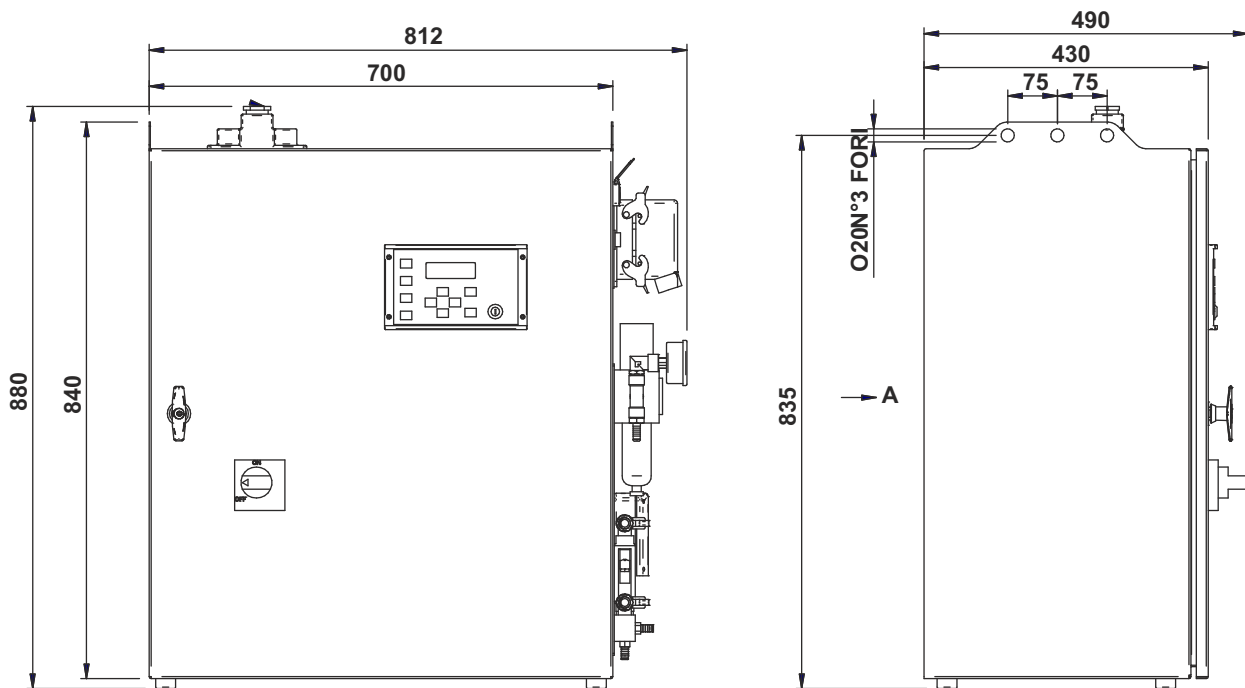

			1556W	1557W	1558W
ALIMENTAZIONE	MAINS SUPPLY	SPEISUNG	400V - 440V - 460V* - 480V* TRIFASE -20%		
FREQUENZA DI	INPUT FREQUENCY	EINGANGSFREQUENZ	50 / 60 Hz		
FREQUENZA DI LAVORO	WORKING	BETRIEBSFREQUENZ	1000-2000-3000-4000 Hz		
CORRENTE IN USCITA	OUTPUT CURRENT	AUSGANGSSTROM	500 A	700 A	1000 A
TENSIONE IN USCITA	OUTPUT VOLTAGE	AUSGANGSSPANNUNG	520V - 550V - 600V		
TIPO DI	COOLING TYPE /	KHLUNGSTYP/	ACQUA >15°C <30°C		
LITRI/MINUTO	LITERS/MINUTE	LITER/MINUTE	4-6 LITRI/MIN.		
PRESSIONE DELLACQUA	WATER PRESSURE	WASSERDRUCK	6 bar MAX.		
TEMPERATURA	ROOM	UMGEBUNGSTEMPERATUR	0°C 40°C		
UMIDITA RELATIVA	RELATIVE HUMIDITY	RELATIVE	90% MAX		
DIMENSIONI	DIMENSIONS	ABMESSUNGEN	812 x 490 x 880(h)		
PESO	WEIGHT	GEWICHT	91Kg	93Kg	99Kg

1556W - 1557W - 1558W

9366-9367

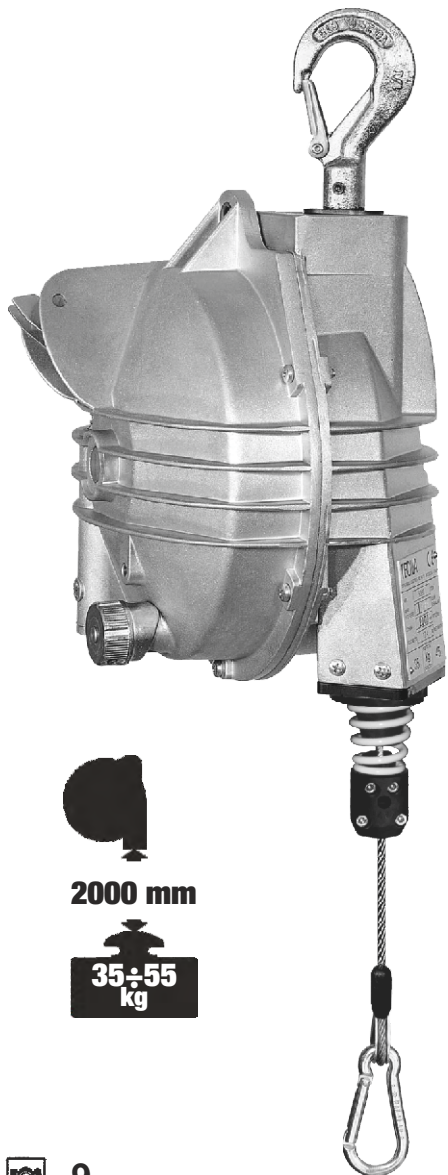

2000 mm
35÷55 kg



9

9405

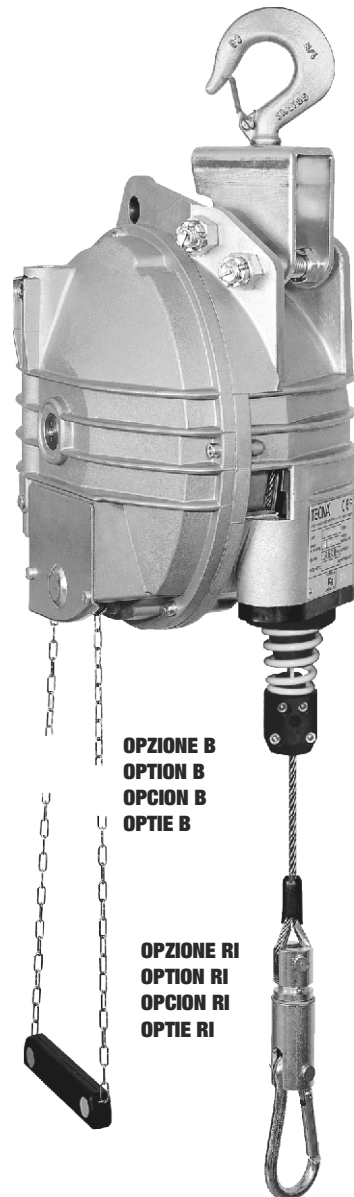

2500 mm
3000 mm
50÷60 kg

OPZIONE B
OPTION B
OPCION B
OPTIE B

OPZIONE RI
OPTION RI
OPCION RI
OPTIE RI



10

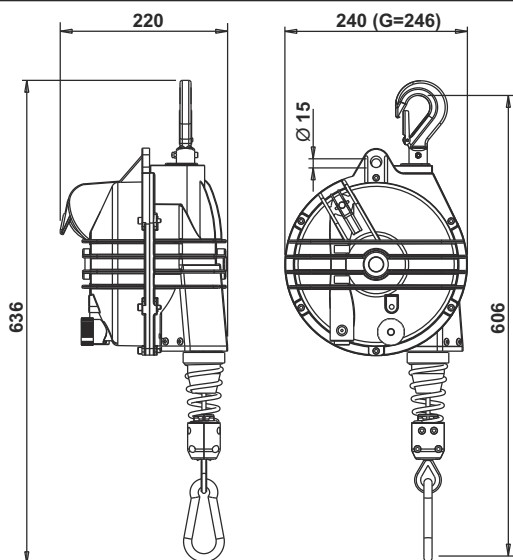

9366-9367

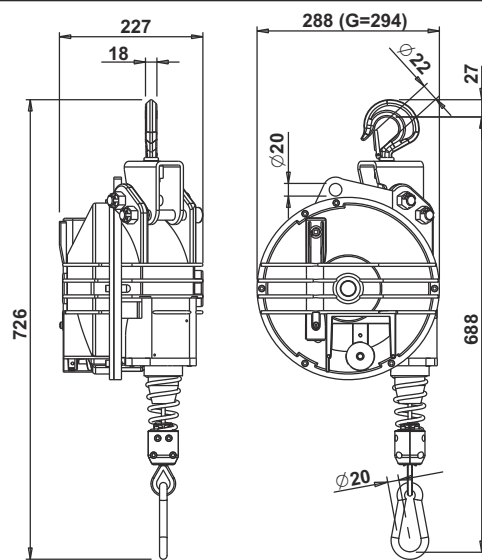

9405

DATI E CARATTERISTICHE TECNICHE - DATA AND FEATURES - TECHNISCHE DATEN

Art.-Item	9366	9367	9405
	35÷45	45÷55	50÷60
	12,4	12,5	25,4

9366-9367-9405

9411-9412-9413-9414

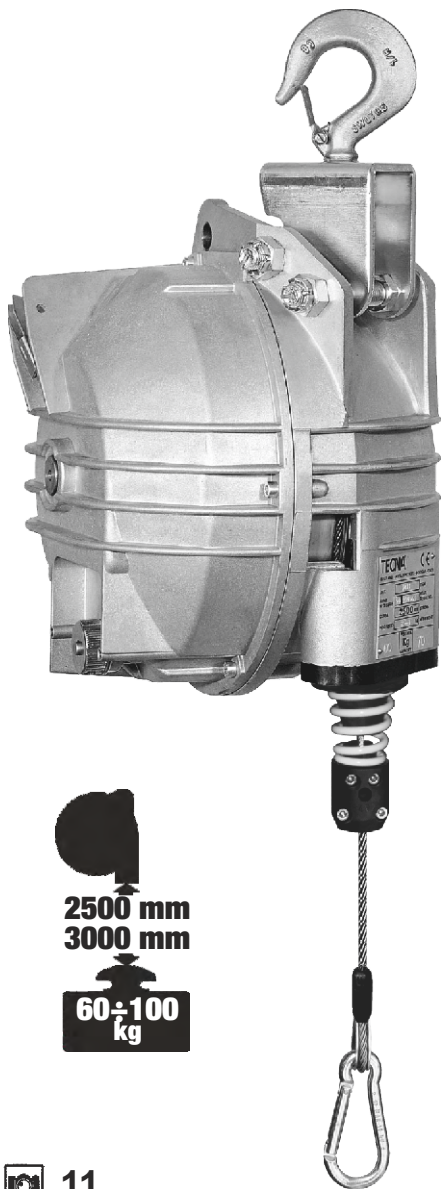

2500 mm
3000 mm
60÷100 kg

11

9422



2500 mm
3000 mm
100÷120 kg

12

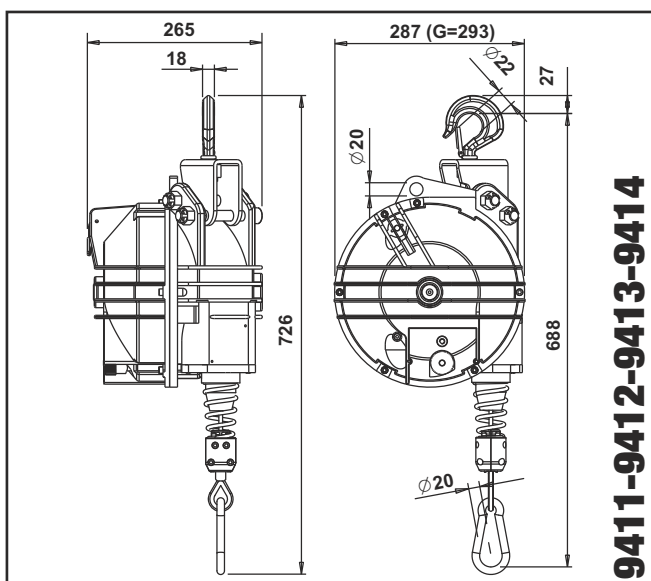

9411-9412-9413-9414

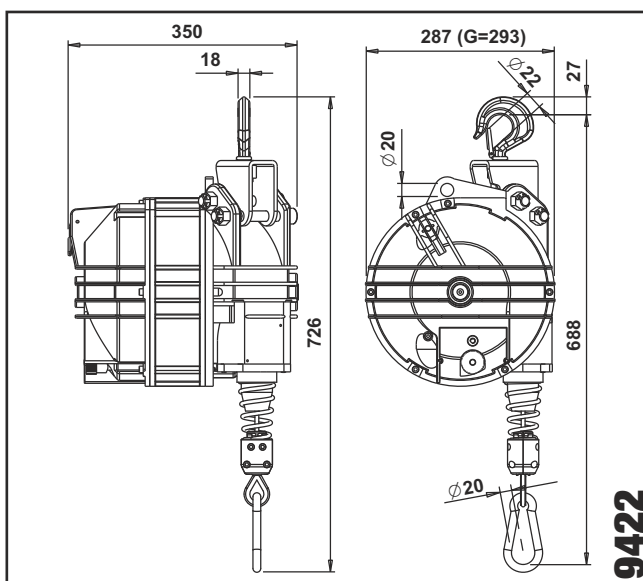

9422

ITALY **DATI E CARATTERISTICHE TECNICHE** - DENMARK **DATA AND FEATURES** - GERMANY **TECHNISCHE DATEN**

Art.-Item	9411	9412	9413	9414	9422
	60÷70	70÷80	80÷90	90÷100	100÷120
	26,8	27,8	28,8	30	38,7

9411-9412-9413-9414-9422

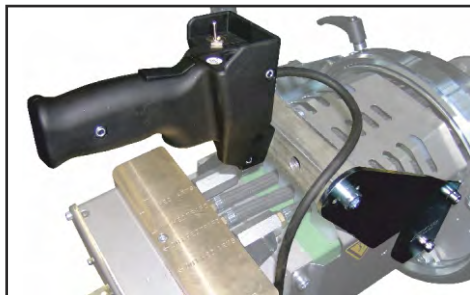

Art./Item 3101 (L-LL-C)
Art./Item 3102 (LG-LLG-CG)

🇮🇹 Supporto per montare l'impugnatura di comando sul lato inferiore della puntatrice pensile.
 🇬🇧 Holder to mount the control handle on the lower side of the spot gun.
 🇩🇪 Halterung für Montage des Schaltgriffes auf der Unterseite der Zange.

📷 13

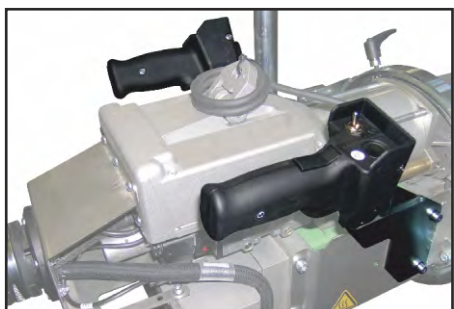

Art./Item 3103 (L-LL-C)
Art./Item 3104 (LG-LLG-CG)

🇮🇹 Supporto per montare l'impugnatura di comando su un lato della puntatrice pensile, completo di seconda impugnatura.
 🇬🇧 Holder to mount the control handle on a spot gun side, complete with another handle.
 🇩🇪 Halterung für Montage des schaltgriffes seitlich der Zange, komplett mit zweitem Griff.

📷 14

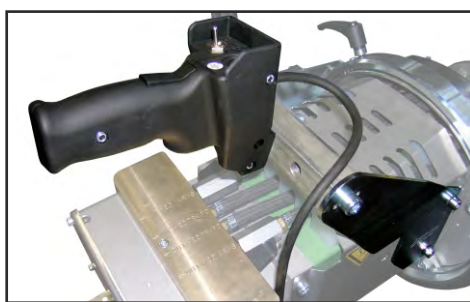

Art./Item 3191 (L-LL-C)
Art./Item 3192 (LG-LLG-CG)

🇮🇹 Supporto per montare la seconda impugnatura di comando attiva sul lato inferiore della puntatrice pensile.
 🇬🇧 Holder to mount the extra active control handle on the lower side of the spot gun.
 🇩🇪 Halterung für Montage des zweiten aktiven Schaltgriffes auf der unteren Seite der Zange.

📷 15



Art./Item 3193 (L-LL-C)
Art./Item 3194 (LG-LLG-CG)

🇮🇹 Supporto per montare l'impugnatura di comando su un lato della puntatrice pensile e secondo supporto completo di seconda impugnatura di comando attiva.
 🇬🇧 Holder to mount the control handle on a spot gun side and extra support complete with extra active control handle.
 🇩🇪 Halterung für Montage des Schaltgriffes seitlich der Zange und zweite Halterung komplett mit dem zweiten aktiven Schaltgriff.

📷 16



Art./Item 3180

🇮🇹 Valvola proporzionale. Consente di regolare la pressione di lavoro direttamente dall'unità di controllo e di associare ad ogni programma il proprio valore di pressione. Garantisce una elevata precisione e costanza della pressione di lavoro.
 🇬🇧 Proportional valve. Allows to adjust the working pressure directly from the control unit and to combine a proper pressure value to each program. Assures constant and accurate working pressure.
 🇩🇪 Proportionalventil. Ermöglicht die Arbeitsdruckeinstellung direkt auf der Steuerung und jedem Programm kann der eigene Druckwert zugeordnet werden. Gewährleistet Präzision und konstanten Arbeitsdruck.

📷 17