

TECNA®



Advanced Resistance Welding Systems and Balancers

-  KIT DI SALDATURA A MEDIA FREQUENZA E TRASFORMATORE
-  MEDIUM FREQUENCY WELDING KIT AND TRANSFORMER
-  KIT DE SOUDAGE ET TRANSFORMATEUR A MOYENNE FREQUENCE
-  MITTELFREQUENZ-SCHWEISSKIT UND TRANSFORMATOR
-  KIT DE SOLDADURA DE MEDIA FRECUENCIA Y TRANSFORMADOR



The most advanced resistance welding machines

www.tecna.net

UNITA' DI CONTROLLO A MEDIA FREQUENZA
MEDIUM FREQUENCY CONTROL UNIT

UNITÉ DE CONTRÔLE À MOYEN FRÉQUENCE
MITTELFREQUENZ-STEUERUNG
UNIDAD DE CONTROL DE MEDIA FRECUENCIA



Inverter Type [Art./Item]	Primary Current [A]
1591A	150
1591B	150
1592NA	300
1593NA	600
1594W	900
1596NW	1500

TRASFORMATORI
TRANSFORMERS

TRANSFORMATEUR
TRANSFORMATOR
TRANSFORMADOR

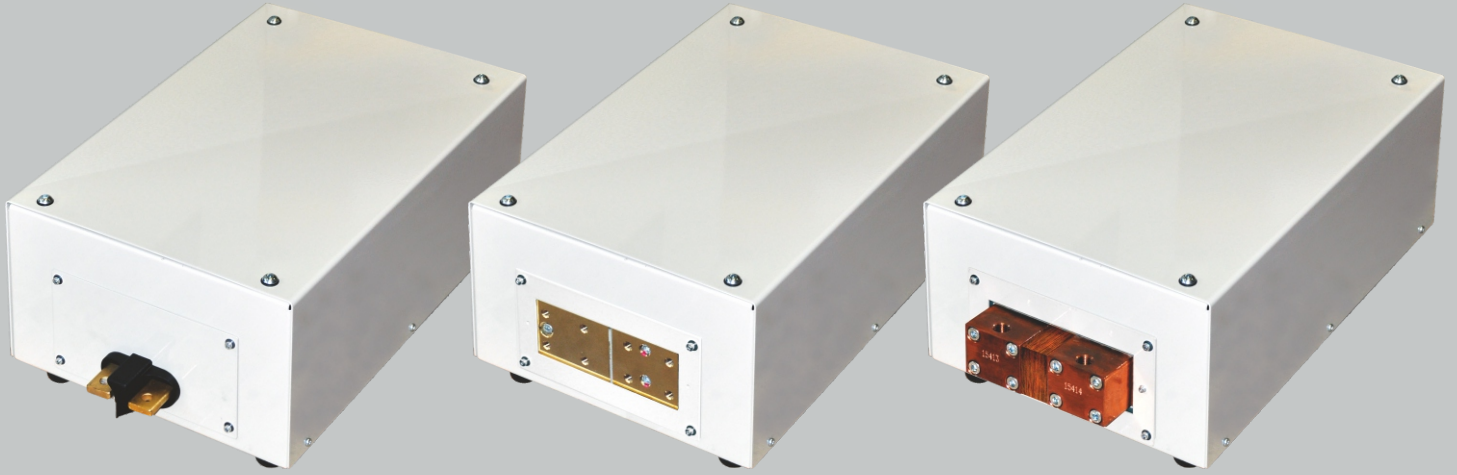

1587

1584 | 1585

1588 | 1589

TRANSFORMERS					
Transformer Type [Art./Item]	Power at 20% [kVA]	Power at 50% [kVA]	Secondary voltage [V]	Maximum weld current I_{200} [kA]	Permanent out put current I_{2p} [kA]
1587	40	25	14,5	9	4,3
1584	88	56	8	25	4,4
1585	142	90	9,4	32	5,4
1588	190	120	17,7	19	6,6
1589	205	160	12,3	40	8,8



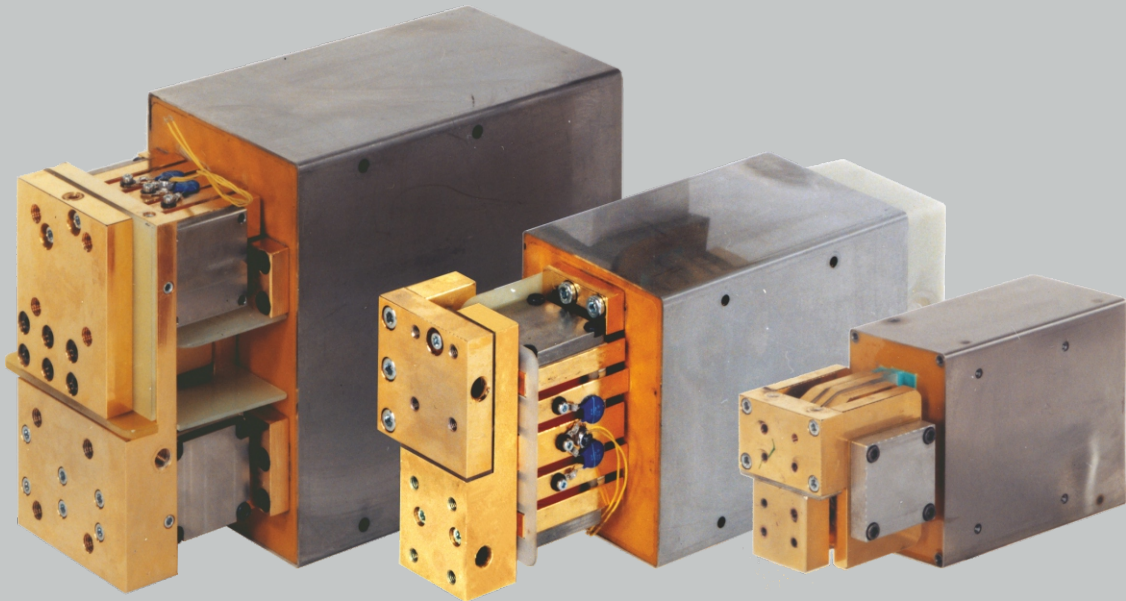

TRASFORMATORI
TRANSFORMERS

TRANSFORMATEUR
TRANSFORMATOR
TRANSFORMADOR







TRANSFORMERS

Transformer Type [Art./Item]	Power at 20% [kVA]	Power at 50% [kVA]	Secondary voltage [V]	Maximum weld current I_{2cc} [kA]	Permanent out put current I_{20} [kA]
40443	40	25	14,2	9	4,3
40365	50	32	4,6	19	4,4
43737	80	51	6,1	19	5,4
40138	88	56	8,4	25	4,5
40139	142	90	9,9	32	6,1
37610	250	160	12,3	40	8,8
40314	316	200	10,4	60	15,3
40315	332	210	12	60	15,3
40266	380	240	10,9	75	15,9
40291	500	315	12,7	75	16,7

ARTICOLO ITEM ARTICLES ARTIKEL ARTICOLO			TE751	TE700	
			1591B	159XNA	1591A 1594W 1596NW
	72288	Kit sensore di posizione Position sensor kit Kit senseur de position Kit Positions-Sensor Kit sensor de posición	-	○	○
	72278	Scheda di interfaccia USB USB interface board Carte interface USB	-	○	○
	72248	Schnittstelle USB Tarjeta de interfaz USB	○	-	-
	50200	Scheda di espansione per campagna elettrodi Expansion board for electrodes dressing Carte d'expansion pour l'affûtage des électrodes Expansions-Printplatte für Elektrodenfräsung Tarjeta de expansión para afiladores electrodos	-	○	○
	72569	Scheda di interfaccia ETHERNET ETHERNET interface board Carte interface ETHERNET Schnittstelle ETHERNET Tarjeta de interfaz ETHERNET	-	○	○
	50220	Scheda per il pilotaggio di valvola proporzionale Board for controlling the proportional valve Carte pour le pilotage de la vanne proportionnelle Printplatte für Verwaltung Proportionalventil Tarjeta de control válvula proporcional	-	○	○

○ OPZIONALE. OPTIONAL. OPTIONNEL. OPTION OPCIONAL.

- NON DISPONIBILE. NOT AVAILABLE. PAS DISPONIBLE. NICHT VERFÜGBAR. NO DISPONIBLE.

ARTICOLO ITEM ARTICLES ARTIKEL ARTICOLO				TE751	TE700	
				1591B	159XNA	1591A 1594W 1596NW
	50300	Profibus	Modulo BUS di CAMPO FIELD Bus module Module des BUS de CHAMP Modul FIELD Bus Módulo de Bus de CAMPO	-	○	-
	50301	Devicenet				
	50302	CanOpen				
	50303	ETHERCAT				
	50304	Profinet				
	50305	EtherNet/IP				
	50307	Modbus RTU				
	72219	Profibus	Modulo BUS di CAMPO FIELD Bus module Module des BUS de CHAMP Modul FIELD Bus Módulo de Bus de CAMPO	-	-	○
	72220	Devicenet				
	72221	CanOpen				
	72222	ETHERCAT				
	72772	Profinet				
	72773	EtherNet/IP				
	73388	Modbus RTU				
	23287	TECNA Net		-	○	○
	50365	TE71	Terminale di programmazione Programming terminal Terminal de programmation Programmierungsterminal Terminal de programación	-	○	○
	73225	Kit Pirometro Pyrometer Kit Kit Pyromètre Pyrometer-Kit Kit de Pirómetro		-	○	○

○ OPZIONALE. OPTIONAL. OPTIONNEL. OPTION OPCIONAL.

- NON DISPONIBILE. NOT AVAILABLE. PAS DISPONIBLE. NICHT VERFÜGBAR. NO DISPONIBLE.

Art. / Item 1591A | 1591B

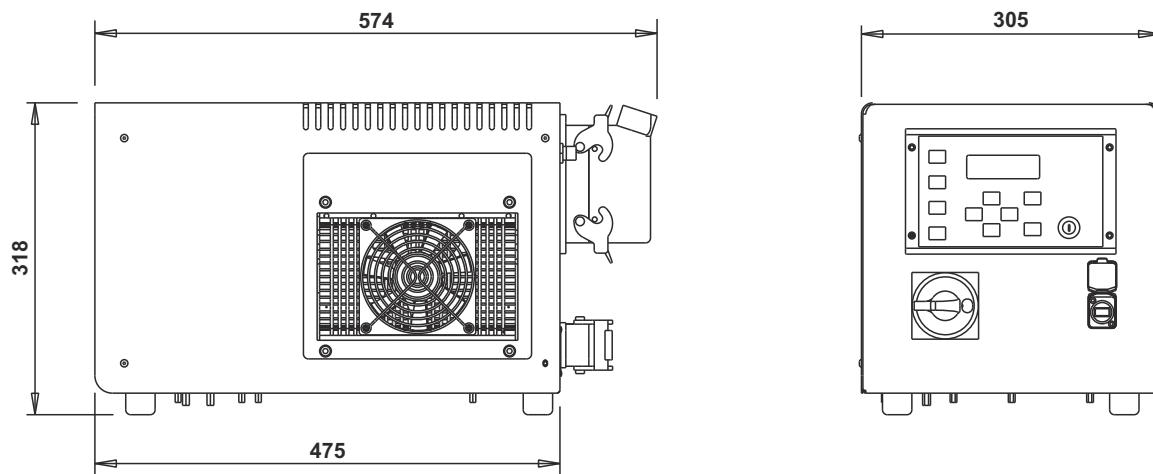

Art. / Item 1592NA | 1593NA | 1594W | 1596NW

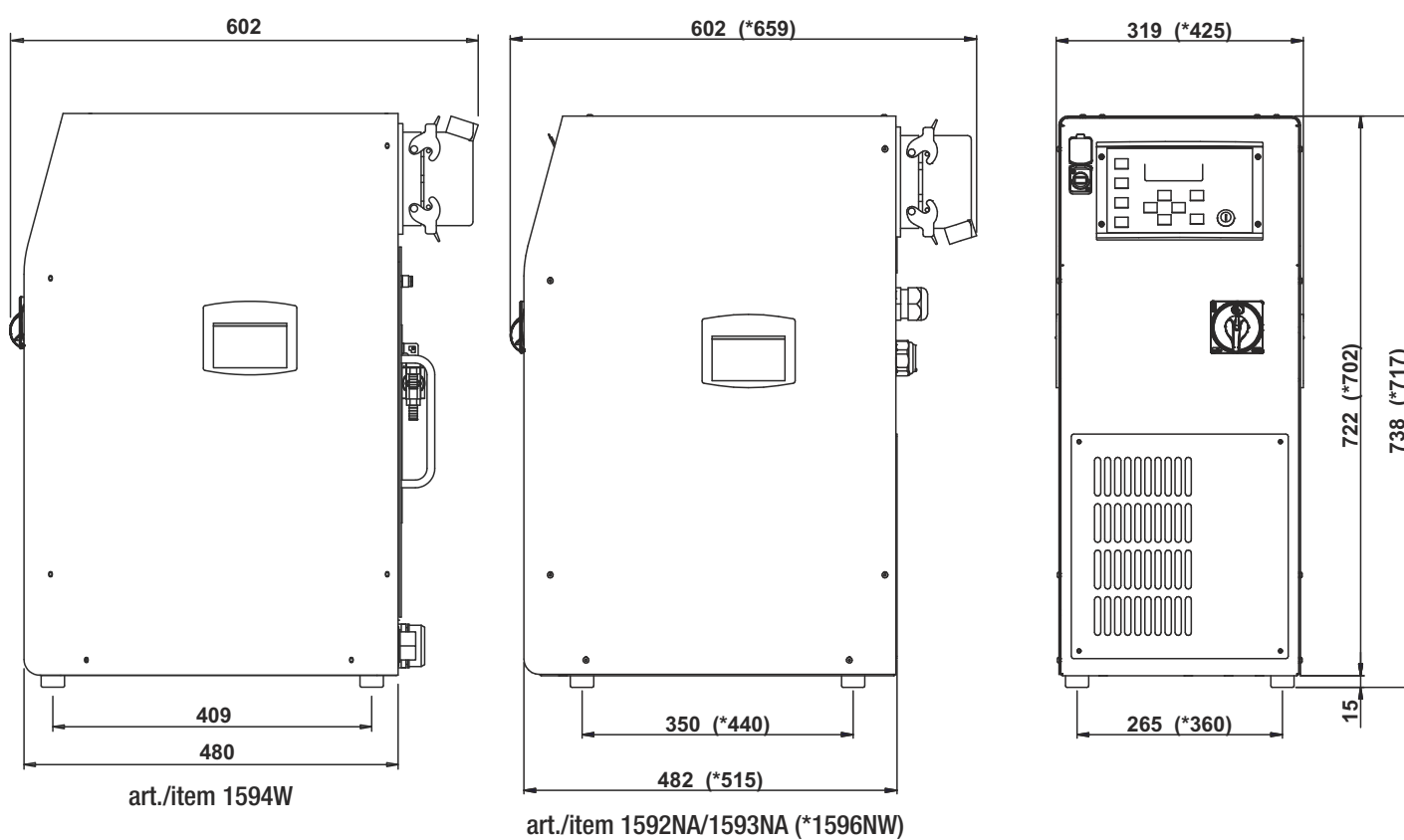

*solo per art. 1596NW | *only for item 1596NW | *seulement pour l'art. 1596NW | *nur für die Kunst. 1596NW | *solamente para el art. 1596NW

Art. / Item 1584 | 1585 | 1587 | 1588 | 1589

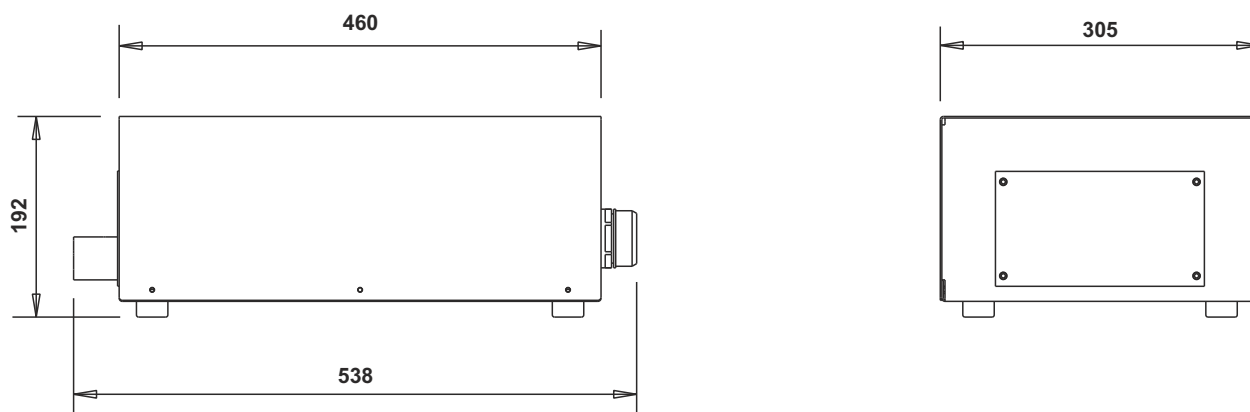

Sede Legale - Uffici - Produzione Linea Industriale - Spedizioni
GPS N44° 24' 24" - E11° 35' 13"



Stabilimento di Produzione Linea Bilanciatori
Via Miglioli, 36 | Castel San Pietro Terme | GPS N44° 24' 18" - E11° 34' 44"



Stabilimento di Produzione Linea Industriale e Linea Professionale
Via Grieco, 25/27 | Castel San Pietro Terme | GPS N44° 24' 18" - E11° 34' 44"



World leader
in Resistance Welding

TECNA[®]



Advanced Resistance Welding Systems and Balancers

TECNA S.p.A. | Via Meucci, 27 | 40024 | Castel S. Pietro Terme | Bologna (Italy)
Ph. +39.051.6954400 | Fax +39.051.6954490
<http://www.tecna.net> | E-mail: sales@tecna.net | vendite@tecna.net